

## 932 Sequence Control Circuit

A typical sequence circuit is shown below. It includes five R-932 sequence modules, two R-402 4-way modular valves, (power valves) and two cylinders, each equipped with two limit valves. This typical circuit is designed for Cylinder A to extend and return, then Cylinder B to extend and return.

In inactive mode, LVA- and LVB- are held passing, supplying pressure to port 8 of both SM3 and SM5. The valves will not actuate because there is air already at port 6 which connects to a larger pilot.

When the start button is actuated, pilot pressure is applied to SM1, shifting the valve which pressurizes port 4 of power valve "A" (PVA) pressure at its port 4. This shifts PVA, extending the cylinder. When SM1 shifts, it also removes pressure from SM2 at port 6 preparing it for step 2.

Extension of cylinder A actuated LVA+. This shifts SM2, providing pressure to port 6 of PVA which shifts and powers the retraction of Cylinder A. The shifting of SM2 also removes supply from port 4 of step 1 allowing the cylinder retraction, and removes supply from port 6 of SM3, preparing it for step 3.

As a result, when LVA- attains passing position this time, there is no pressure on the larger pilot of SM3. It shifts, providing supply to port 4 of PVB. The power module shifts, with resultant flow extending Cylinder B. The sequence cycle continues through retraction and stops unless the start button remains actuated. Continuous cycling can be accomplished by using a toggle or selector valve for the start button.

Retraction of cylinder B actuates LVB- causing a chain reaction for resetting the sequence valves for the next cycle.

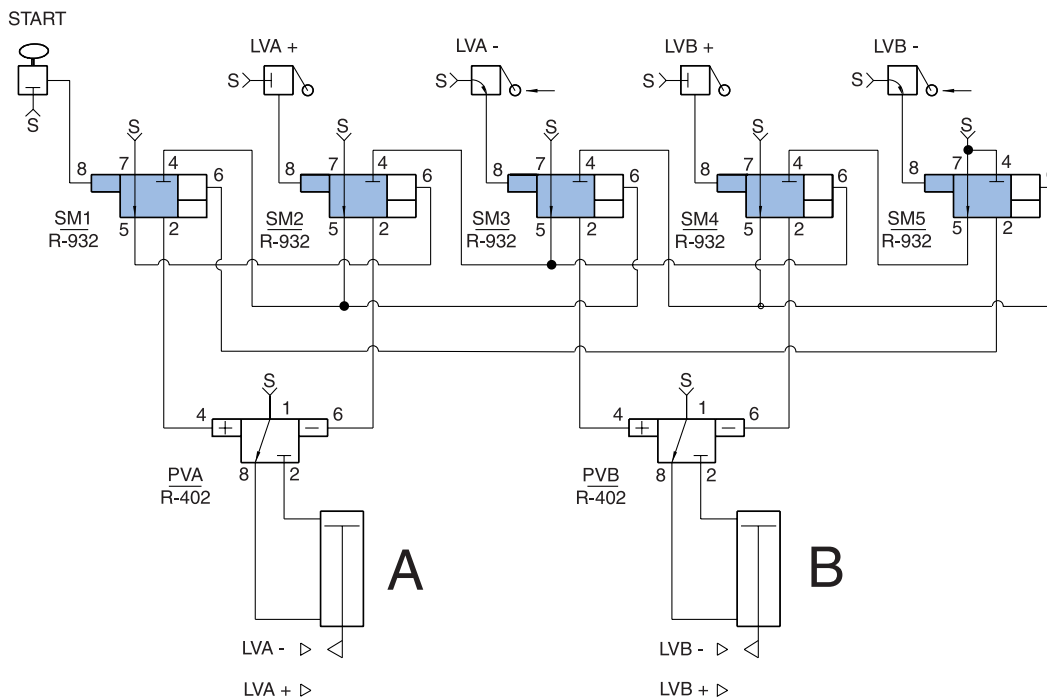

NOTE: The SEQUENCE IS FOLLOWED by the indicator in the valve. The last indicator down is the last step actuated. This is helpful when trouble shooting a circuit.

The circuit described above is an example of a typical sequence circuit. Most applications will require additional functions. Therefore, the number of sequence valves will increase, but the procedure for connections and applications of the R-932 remain.

It is important to remember the input signals can come from other types of input devices such as:

proximity sensors, gap sensors, back pressure sensors, pressure sensors, limit valves, electronic Hall Effect sensing, liquid level sensing, part sensing, etc.

By using modular components found in this catalog, additional functions such as "Delay IN (R-333) "AND" (R-301) can be added to the sequence circuits.

The sequence circuit can also be used with larger air power valves or air piloted hydraulic valves.